



 **ADOWIN**[®]

**60 SERIES
PVC PROFILE SYSTEM**



TECHNICAL

60 SERIES

Profile Width: 60 mm

Number of chambers: 3

Profile Class: B Class (TS EN 12608-1)

Seal Type: External / Internal double seal system

Seal Type and Color: TPE - Grey /Black

Glass Thickness (mm): 4, 20, 24, 30, 32 mm

The thermal insulation Uf: 1,58 W/m²K

- 1** Frame 3 chambers system.
- 2** Offset and flat sash option
- 3** Double and triple glass option.

INSTRUCTION

- The main profile has 60 mm width.
- Because of the elastic grey and black seal which does not leave any stain on profiles will be provided maximum air, water, dust and sound isolation.
- Due to the 3 chambers profiles, it has maximum performance for thermal, sound and water isolation.
- It is a series of profiles with very special design that provides maximum wind resistance on high rise buildings.
- Excluding normal sash profile there is also chance to have a choice for offset type sash profile.
- In addition to white profile a different laminated color range is available.
- 4-5 mm single glazing application of 20, 24, 30, 32 mm glazing beads give us alternatives of using double, triple glazing and panels.
- It provides the visual integrity in the inner surface and the frame-wall connections due to integrated frame with sill profile.

LAMINATED COLORS



**GOLDEN OAK
ST 540**



**DARK OAK
ST 641**



**SWAMP OAK
ST 503**



**LIGHT OAK
ST 515**



**GREY SAND
AS 509**



**GREY
ST 507**



**ANT. GREY
ST 508**

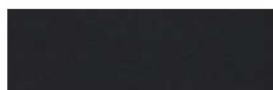

**ANT. GREY
AS 508**



**MAHOGANY
ST 504**



**CREAM
AS 057**

60 SERIES PVC PROFILE SYSTEM

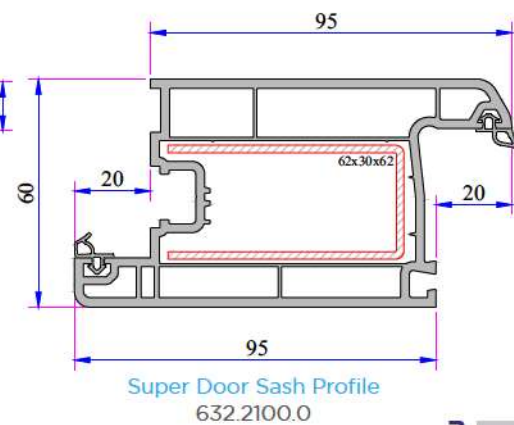
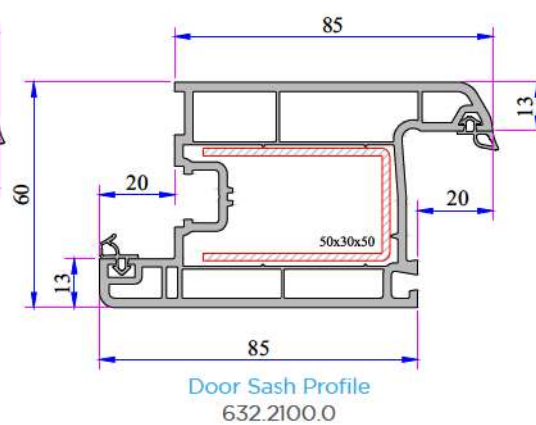
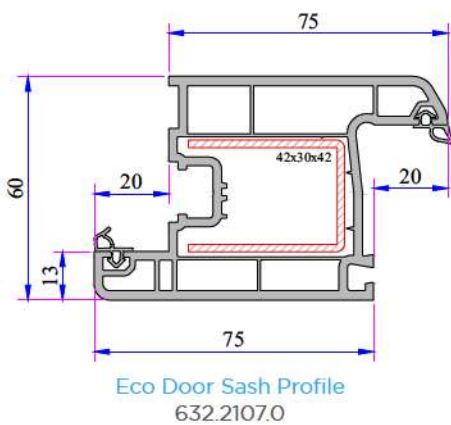
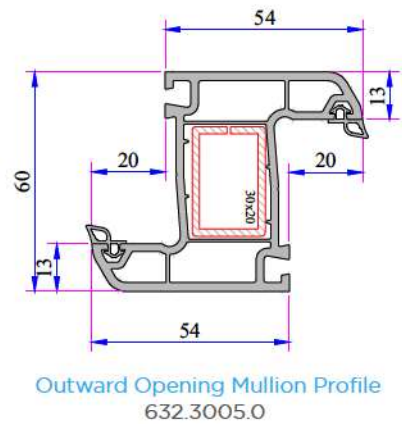
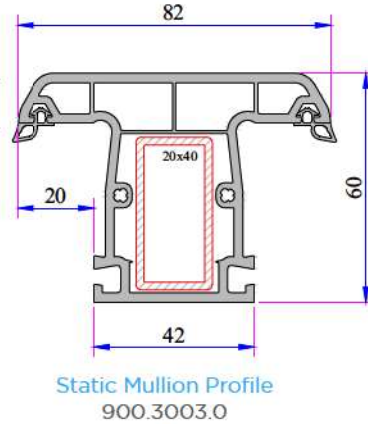
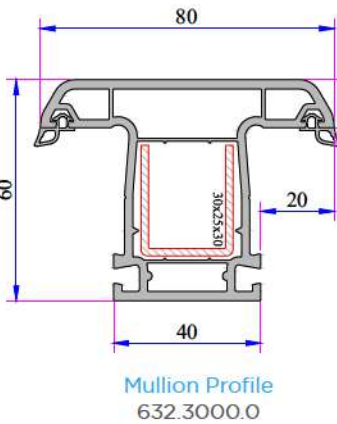
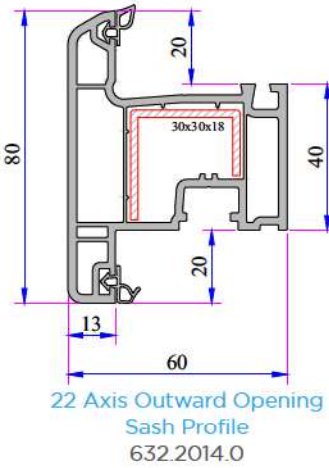
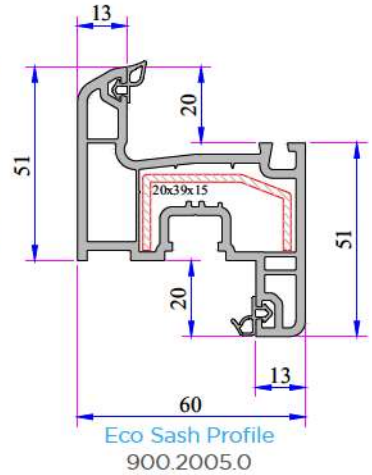
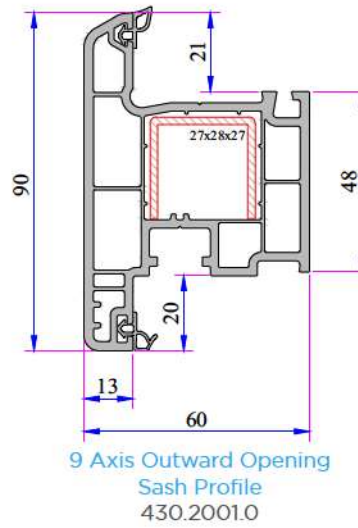
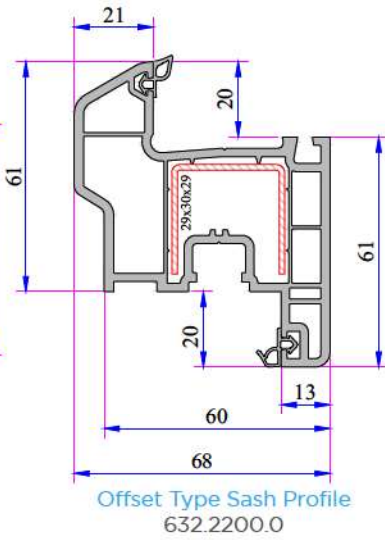
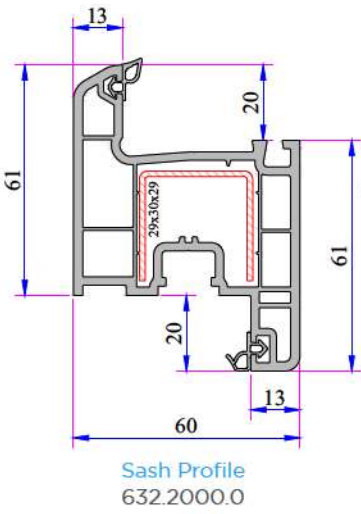
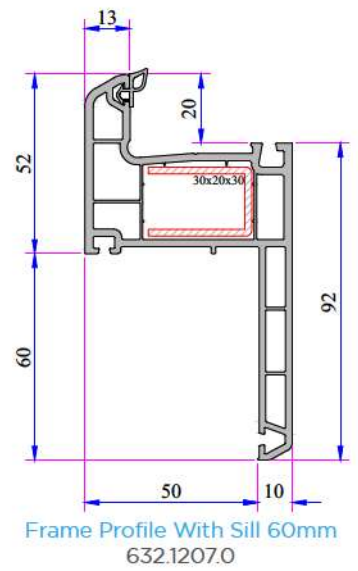
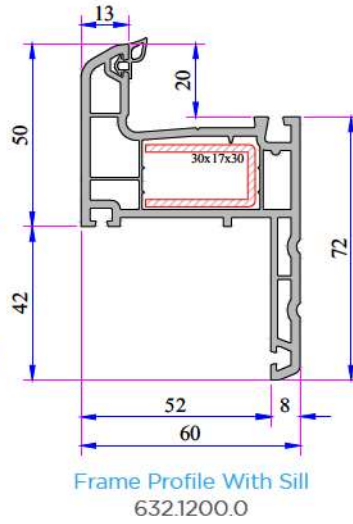
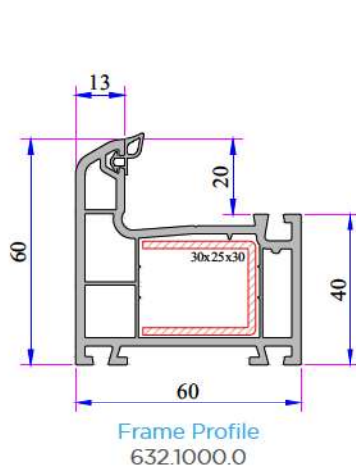
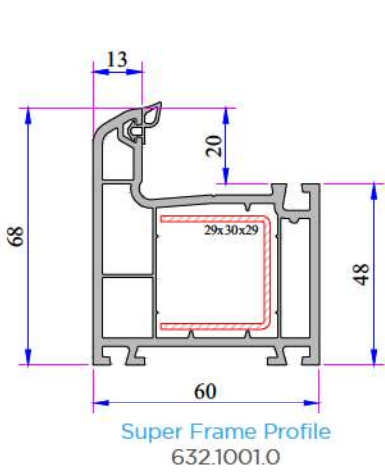

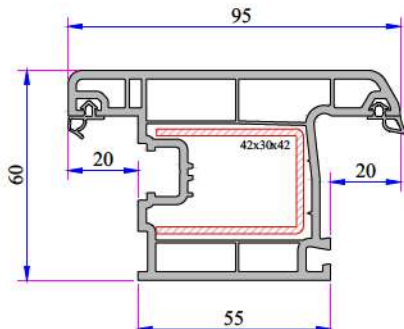

Outward Opening Eco Door Sash Profile
632.2108.0

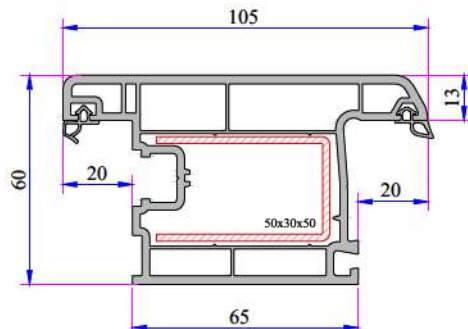

Outward Opening Door Sash Profile
632.2101.0

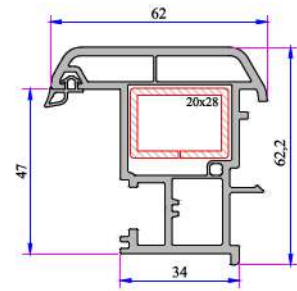

Lap Joint Profile
632.3100.0

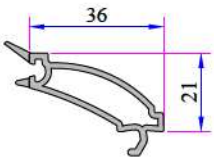

Single Glazing Bead 4-6 mm
101.4002

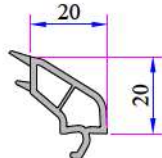

Double Glazing Bead 20 mm
101.4100

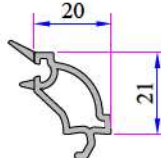

Double Glazing Bead 20 mm
101.4102

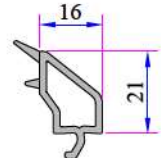

Double Glazing Bead 24 mm
750.4500

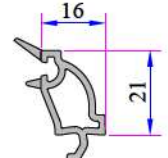

Double Glazing Bead 24 mm
101.4202

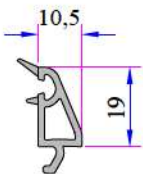

Double Glazing Bead 30 mm
332.4100

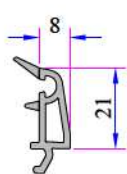

Double Glazing Bead 32 mm
101.4500

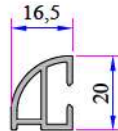

Offset Profile
900.6307

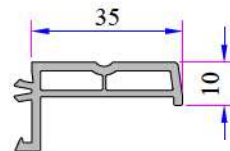

Frame Sill Profile (35mm)
099.5523

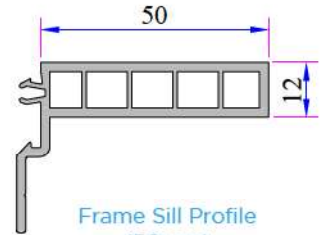

Frame Sill Profile (50mm)
099.5524

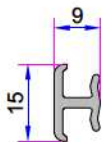

Universal Short Coupling Profile
099.5004



Universal Large Coupling Profile Cover
058.5707

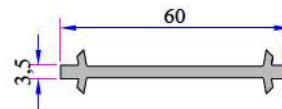

Narrow Couple Profile
060.5001

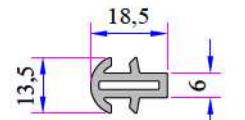

Short Coupling Profile
099.5003

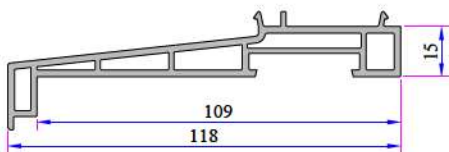

Sill Profile
058.5504

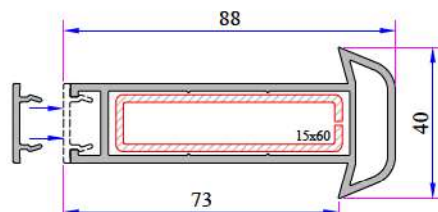

Universal Large Coupling Profile
058.5000

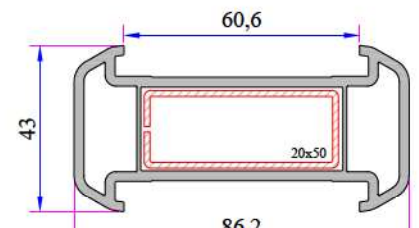

Large Coupling Profile
060.5000

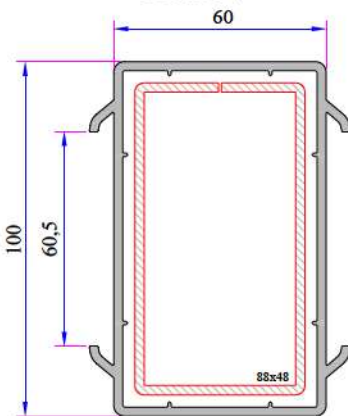

60x100 Spiked Box Profile
060.5203.0.00

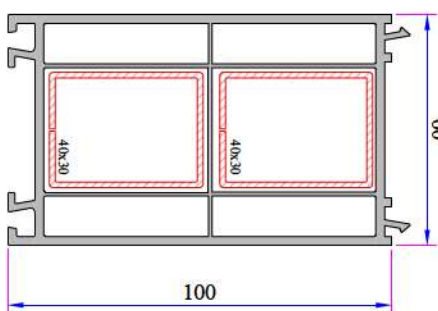

60x100 Frame Lifting Profile
900.5303

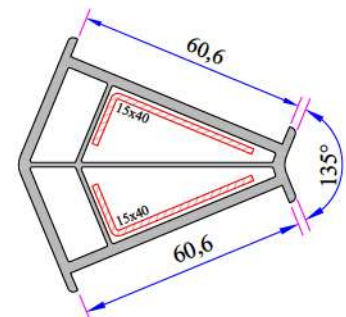

135° Corner Profile
060.5102

60 SERIES PVC PROFILE SYSTEM

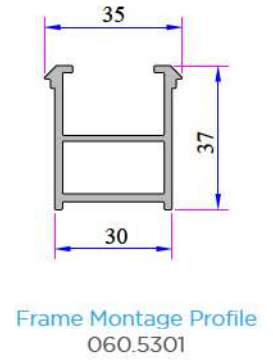
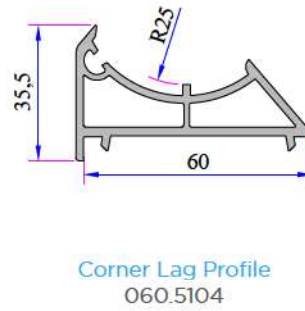
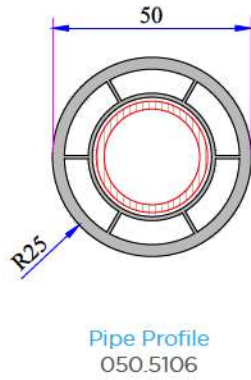
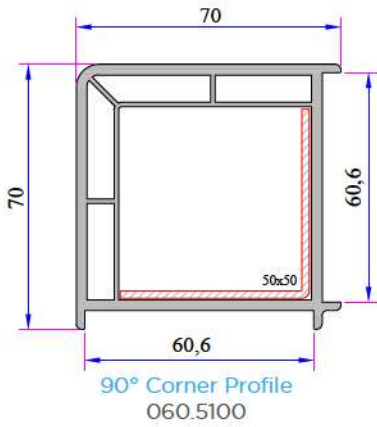

60 Re-Inforcement Profiles

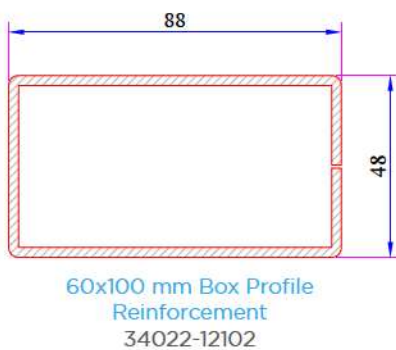
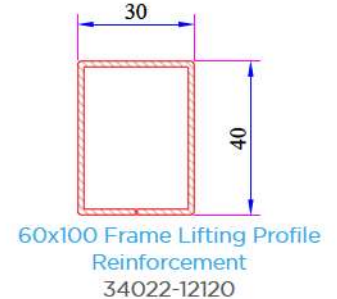
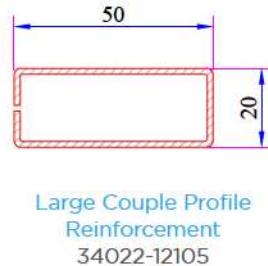
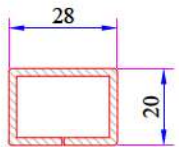
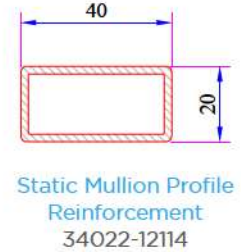
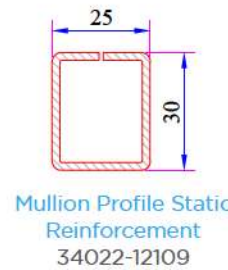
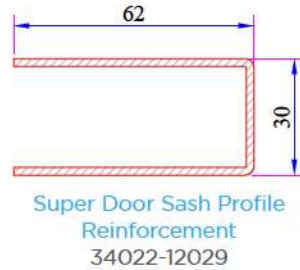
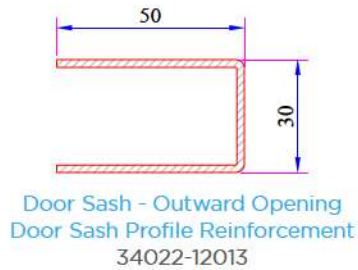
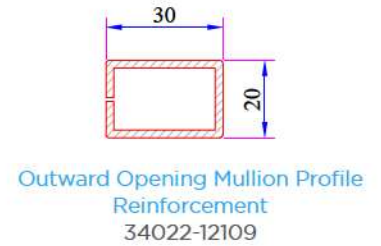
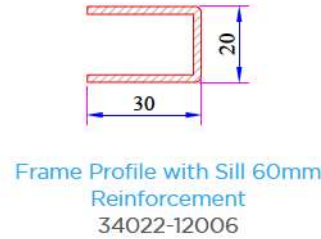
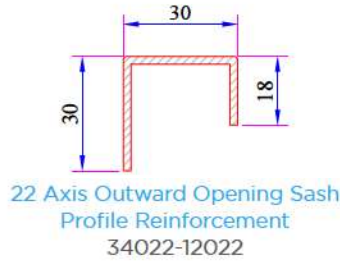
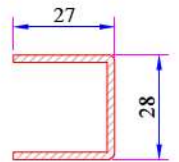
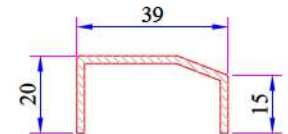
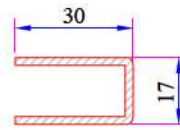
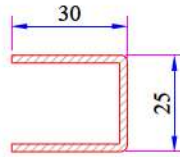
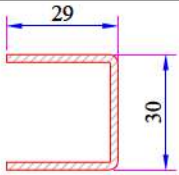

60 Installation

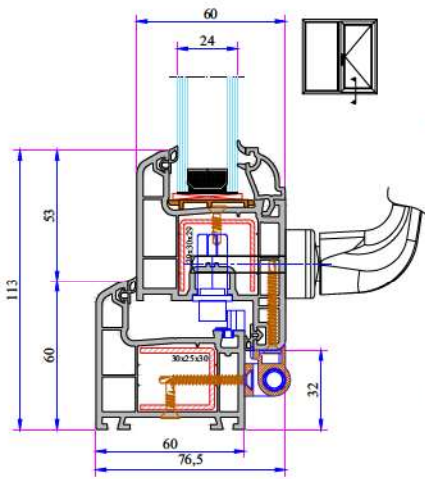

Frame - Sash Installation

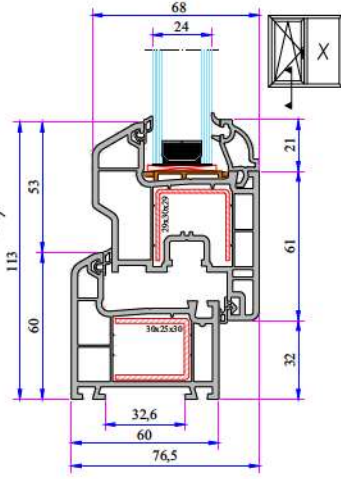

Frame - Offset Type Sash Installation

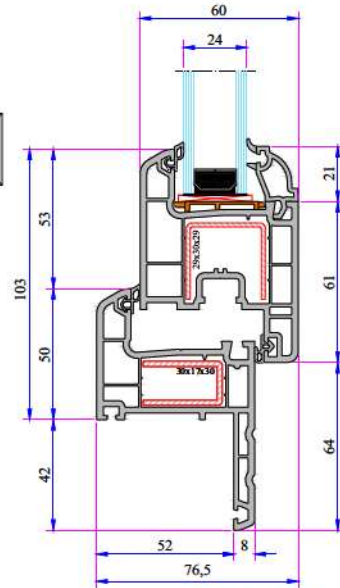

Frame with Sill - Sash Installation

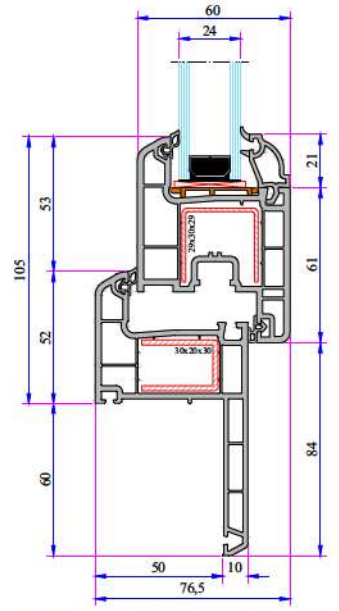

Frame with Sill (60mm) - Sash Installation

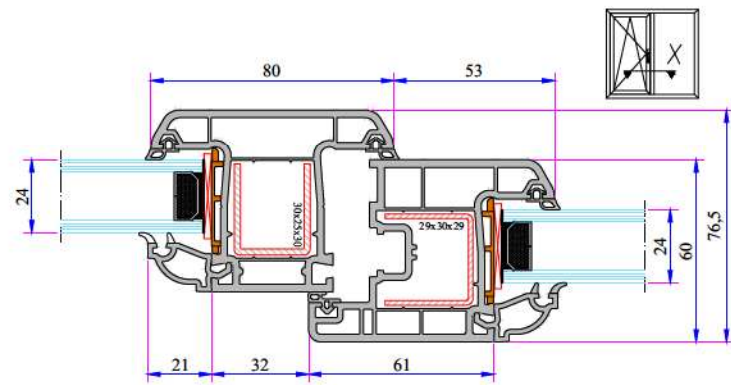

Mullion - Sash Installation

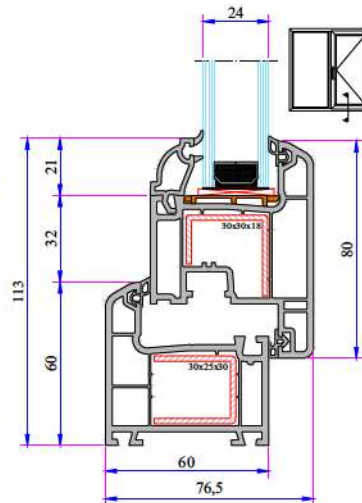

Frame - Outward Opening Sash Installation

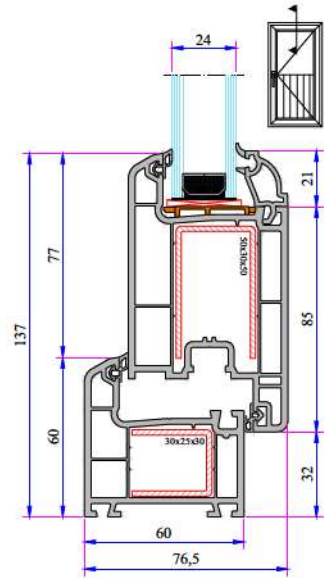

Frame - Door Sash Installation

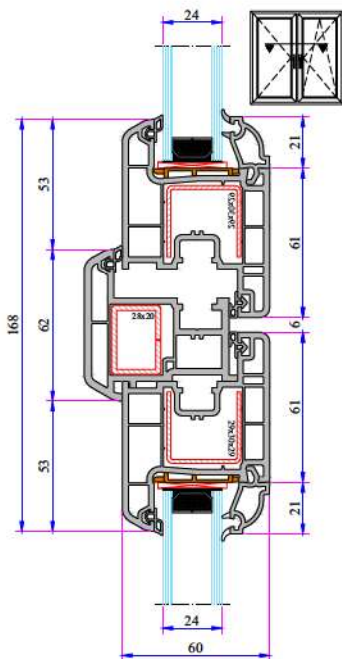

Sash - Lap Joint - Sash Installation

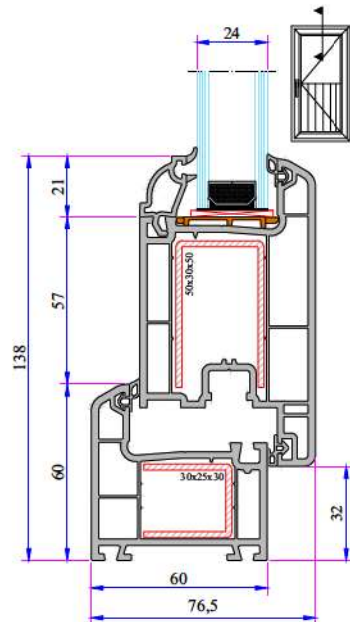

Frame - Outward Opening Door Sash Installation

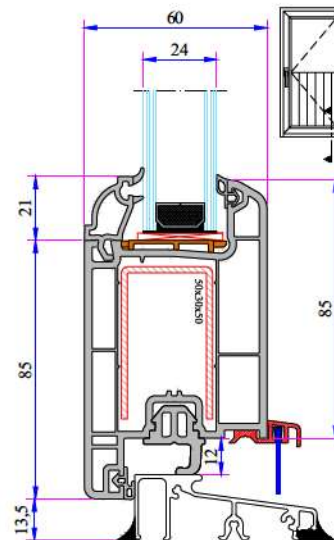

With Aluminium Threshold Frame Door Sash Installation

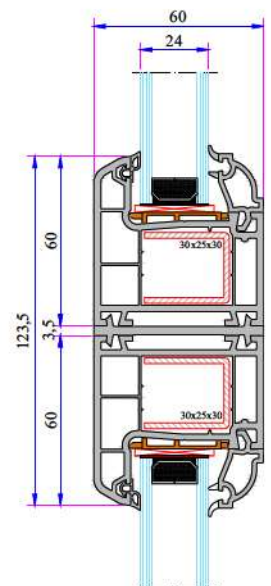

Narrow Coupling Profile Installation

60 SERIES PVC PROFILE SYSTEM

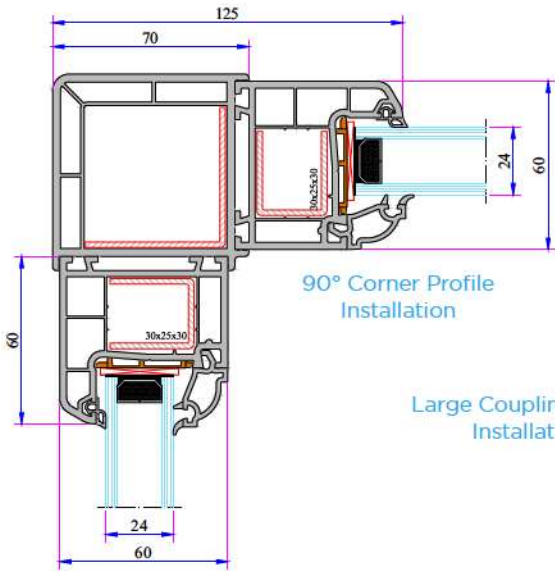

90° Corner Profile Installation

Large Coupling Profile Installation

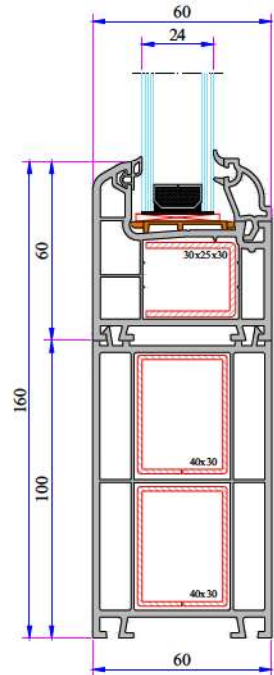
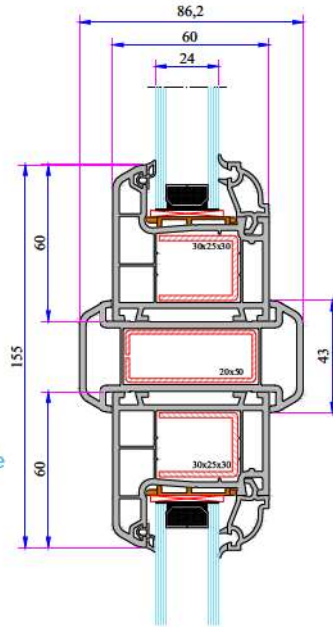

100mm Frame Lifting Profile Installation

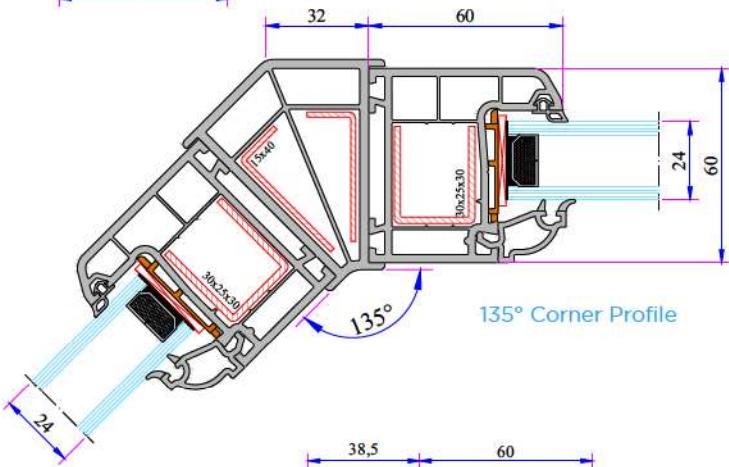

135° Corner Profile

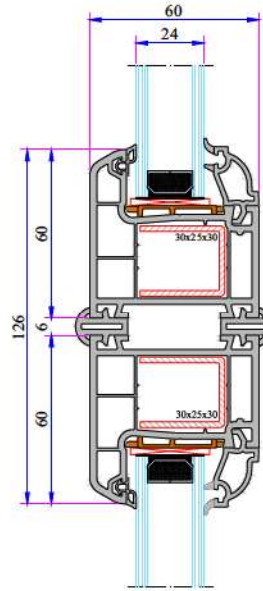

Short Coupling Profile Installation

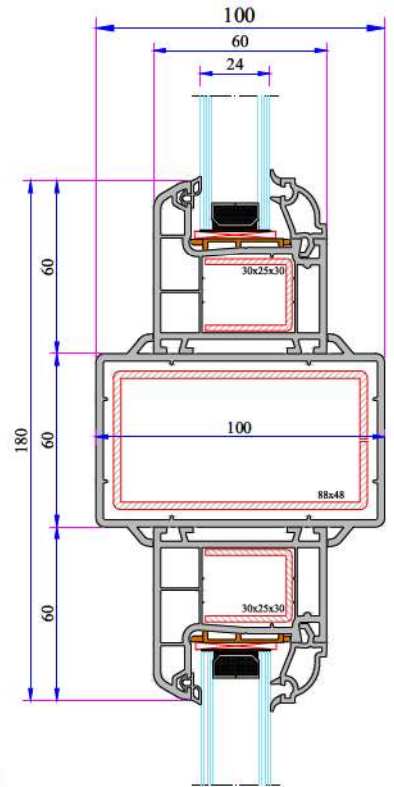

60x100 Box Profile Installation

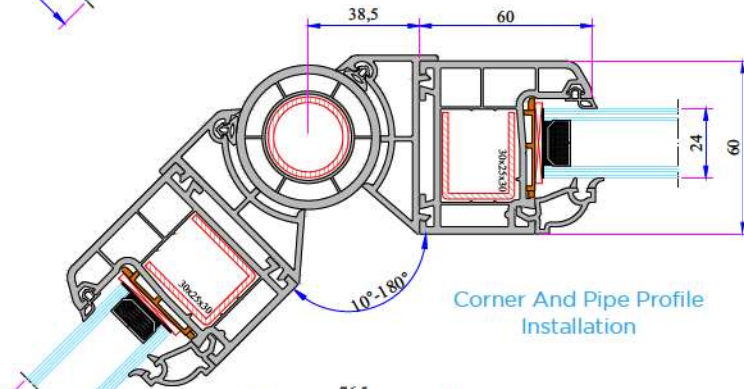

Corner And Pipe Profile Installation

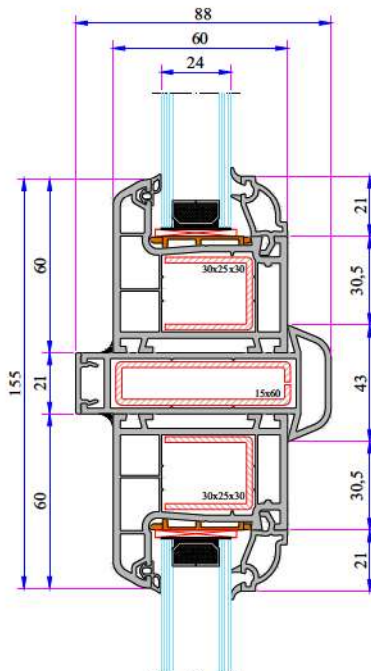

Universal Large Coupling Profile Installation

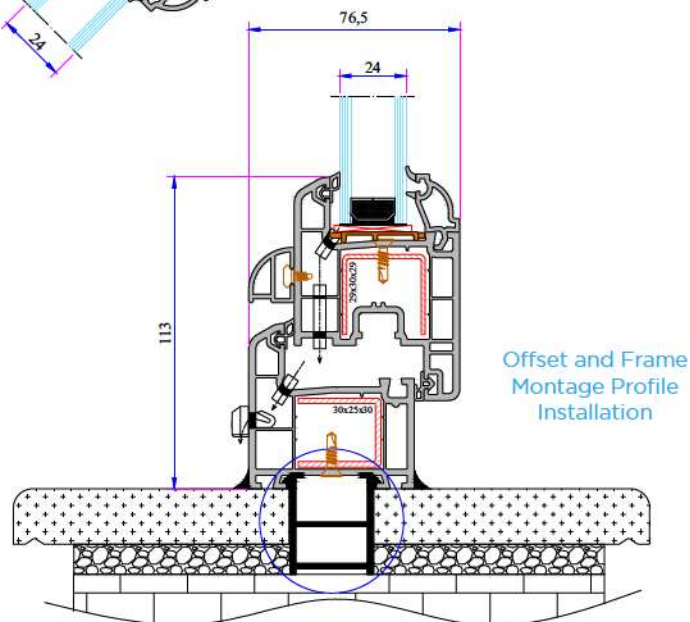

Offset and Frame Montage Profile Installation

Project name:	632 SERI Uf	ADOPEN
Transmittance (Uf):	1.5802 W/m ² K	Internal T: 20.00 °C
Conductance (Lf2D):	0.3545 W/mK	External T: 0.00 °C
Frame length (Bf):	113.00 mm	



Frame
Simulator

Thermal transmittance (Uf) computation performed in accordance with EN ISO 10077-2:2012

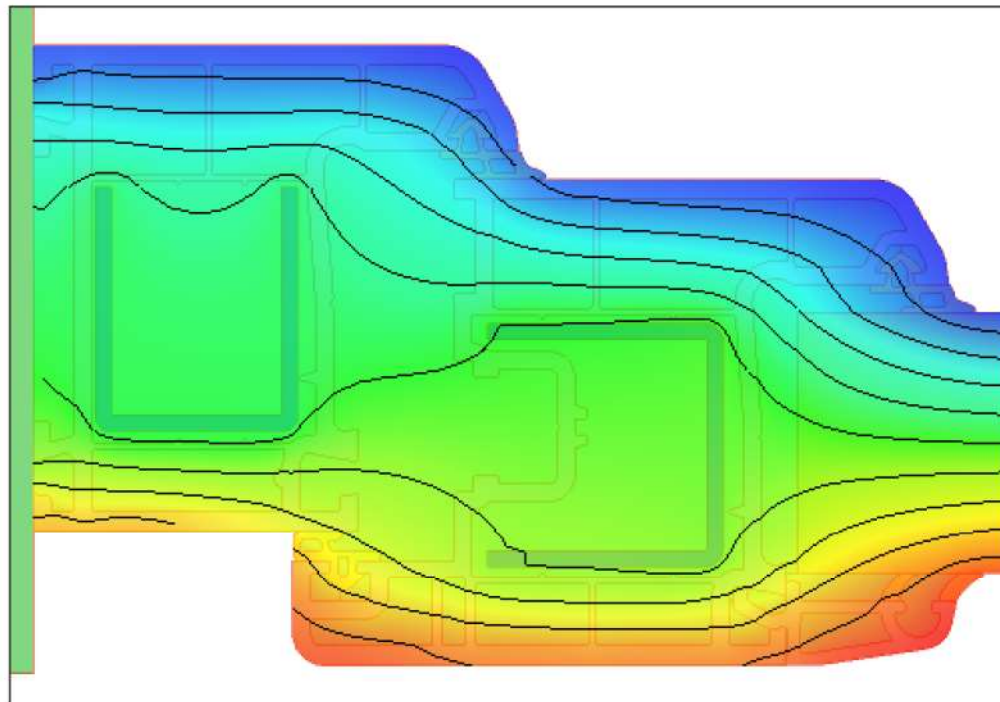

0.45 18.13

Node details

<i>Primitives used for finite element simulation:</i>	18486
<i>Frame width (Bf):</i>	113.00 mm
<i>Visible insulation panel width (Bp):</i>	190.75 mm
<i>Insulation panel thickness (Dp):</i>	35.20 mm

External boundary conditions:

<i>Temperature:</i>	0.00 °C
<i>Surface resistance:</i>	0.040 m ² K/W

Internal boundary conditions:

<i>Temperature:</i>	20.00 °C
<i>Surface resistance:</i>	0.130 m ² K/W
<i>Humidity:</i>	-

Results computed in accordance with EN ISO 10077-2:2012

<i>Internal/external temperature difference:</i>	-
<i>2D conductance (Lf2D):</i>	0.3545 W/mK
<i>Transmittance (Uf):</i>	1.5802 W/m ² K



FACTORY

Antalya Organize Sanayi Bölgesi 2.Kısım Mah. 21.Cadde No:3

07040 Döşemealtı / ANTALYA / TURKEY

Tel : +90 242 236 20 00 · Faks : +90 242 236 20 90 · Email : info@adowin.com.tr

